

**CAST IRON**

**MANHOLE RING AND COVER**

**IMH-310-24-R C.I.**

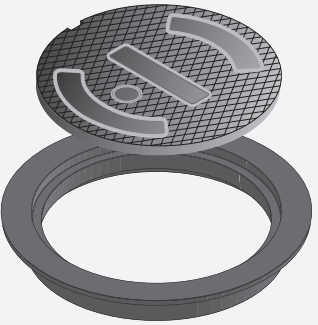

**MH31024RCI**

**APPROXIMATE WEIGHT**

**COVER 136 lb**  
**RING 184 lb**

**CLASS 35**

**NOTES:**  
**NAMEPLATES—CAST AS PER REQUIRED**  
**MACHINING—LID & RING SEAT**  
**FINISH—BLACK BITUMINOUS PAINT**

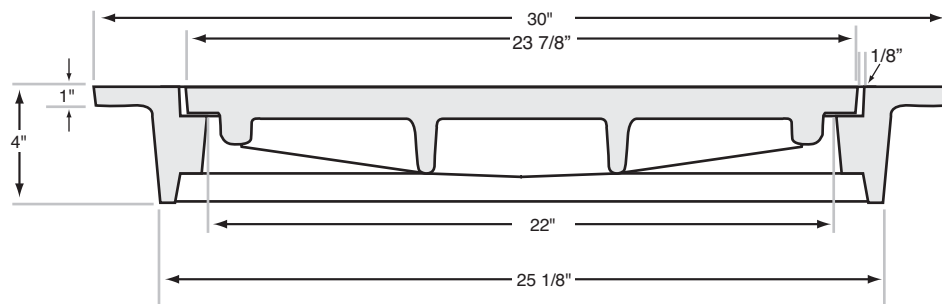
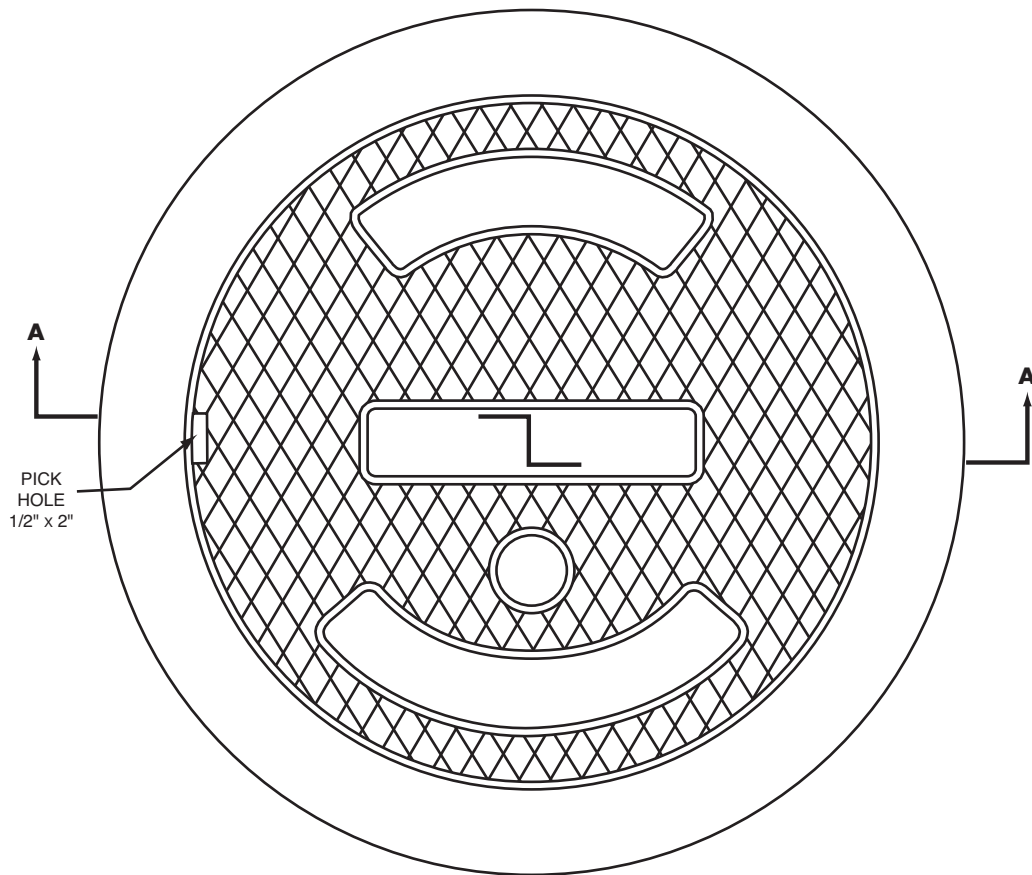

SECTION A-A



**CASTINGS INC.**

860 4TH AVE. • P.O. BOX 669 • GRAND JCT, CO 81502 • 970.243.2032 • FAX 970.242.4962