

**CAST IRON**

**MANHOLE RING AND COVER**

**MH-250-24 BOLT DOWN C.I.**

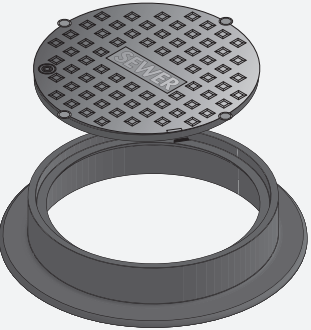

**MH25024CI**

**APPROXIMATE WEIGHT**

**COVER D 120 lb CHECKER**  
**COVER B 134 lb**  
**RING 123 lb**

**NOTES:**  
**NAMEPLATES—CAST AS PER REQUIRED**  
**MACHINING—LID & RING SEAT**  
**FINISH—BLACK BITUMINOUS PAINT**  
**CLASS 35**

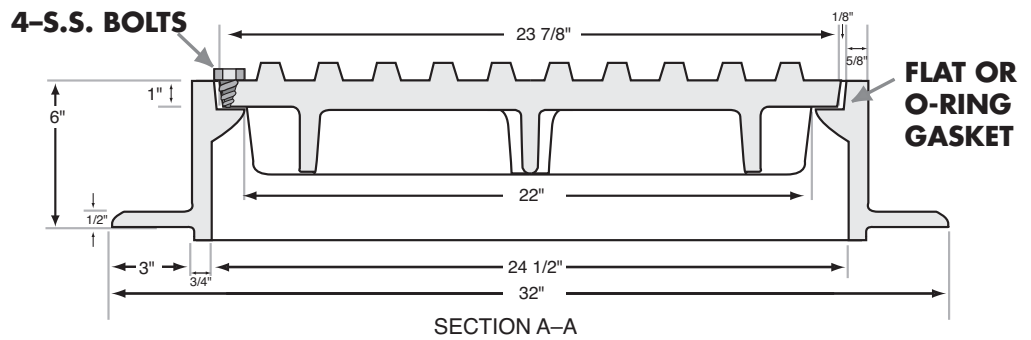
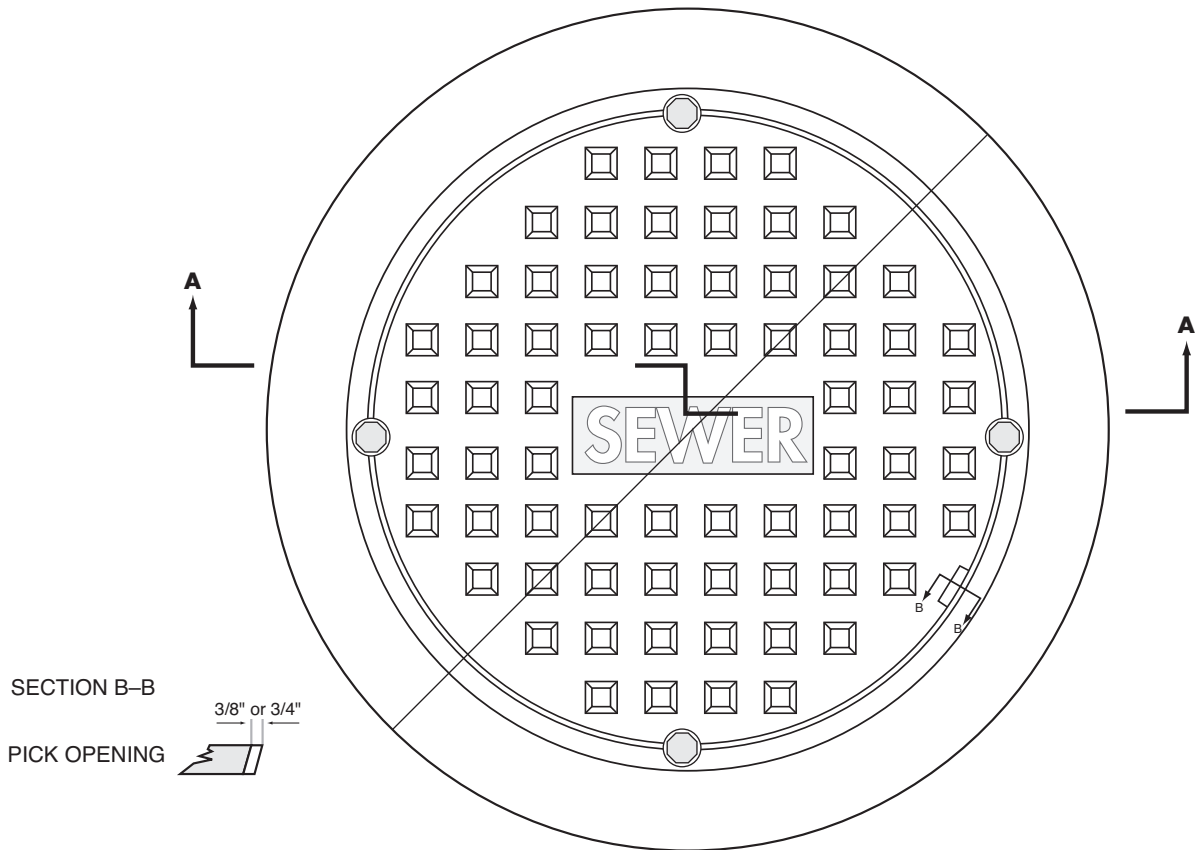

**CASTINGS INC.**

860 4TH AVE. • P.O. BOX 669 • GRAND JCT, CO 81502 • 970.243.2032 • FAX 970.242.4962