

CAST IRON

MANHOLE RING AND COVER

MH-310-24-R C.I.



MH31024RCI

APPROXIMATE WEIGHT

COVER 140 lb
RING 184 lb

NOTES:
NAMEPLATES—CAST AS PER REQUIRED
MACHINING—LID & RING SEAT
FINISH—BLACK BITUMINOUS PAINT
CLASS 35
REVERSIBLE RING

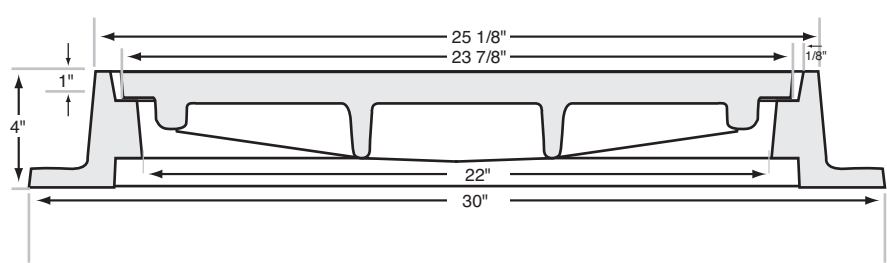
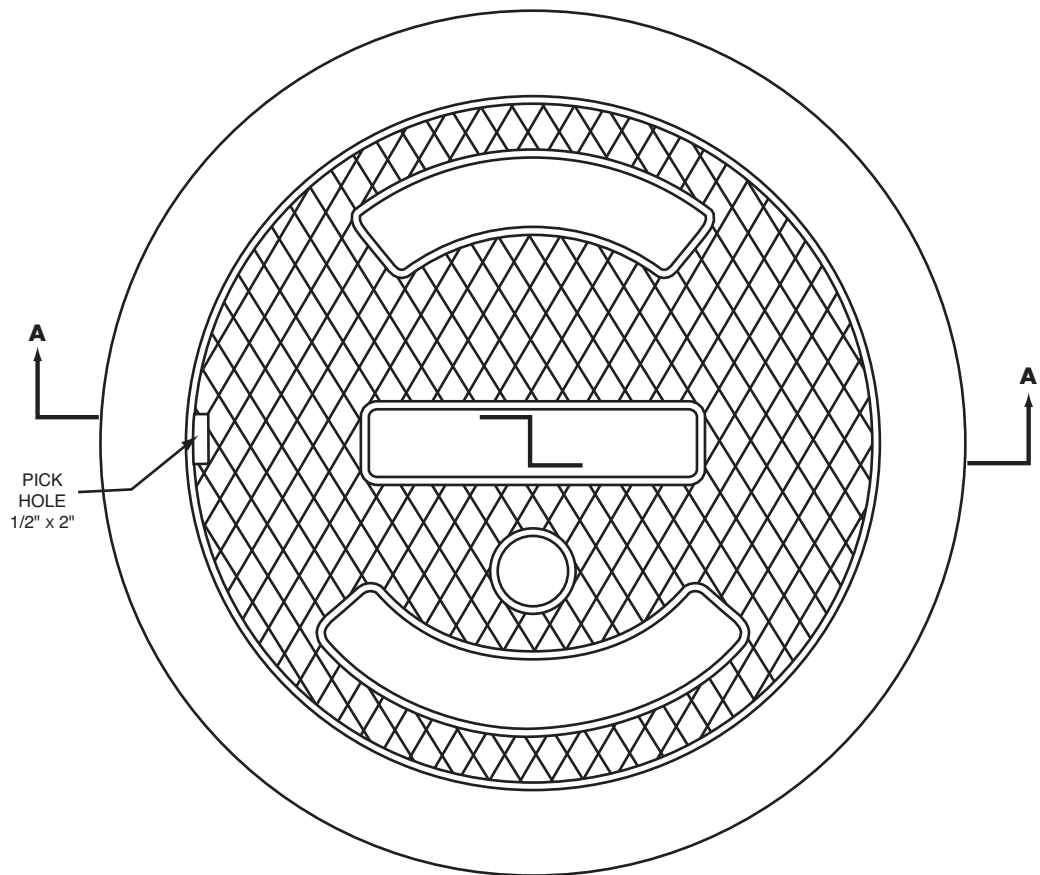

SECTION A-A